

System Operations and Control

Jeff Dagle, PNNL

April 21, 2016

System Operations and Control

Advanced control technologies to enhance reliability and resilience, increase asset utilization, and enable greater flexibility of transmission and distribution systems

Expected Outcomes

- ▶ By 2020 deliver an architecture, framework, and algorithms for controlling a clean, resilient and secure power grid
 - leveraging advanced concepts, high performance computing, and more real-time data than existing control paradigms
 - Involving distributed energy resources as additional control elements
- ▶ Develop software platforms for decision support, predictive operations & real-time adaptive control
- ▶ Deploy through demonstration projects new classes of power flow control device hardware and concepts
- ▶ Advance fundamental knowledge for new control paradigms (e.g., robustness uncompromised by uncertainty)

Federal Role

- ▶ Convening authority to shape vision of advanced grid architecture, including new control paradigms for emerging grid to support industry transformation
- ▶ Deliver system engineering and other supporting capabilities from the National Laboratory System to research & develop integrated faster-than-real-time software platforms and power electronics controls

Conventional controls

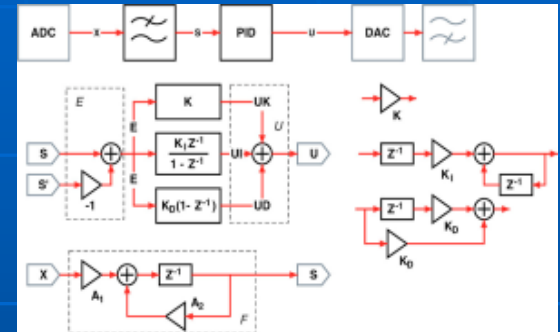

Distributed controls



Roadmap Elements

Activity	Technical Achievements by 2020
1. Develop Architecture and Control Theory	<ul style="list-style-type: none"> • Comprehensive architectural model, associated control theory, and control algorithms to support a variety of applications to improve grid flexibility, future adaptability, and resilience while not compromising operational reliability or security. • Wide-area control strategies to improve reliability, resilience, and asset utilization.
2. Develop Coordinated System Controls	<ul style="list-style-type: none"> • New control grid operating system designs reflecting emerging system control methodologies. • Framework(s) for integrating the next generation energy management system (EMS), distribution management system (DMS), and building management system (BMS) platforms.
3. Improve Analytics and Computation for Grid Operations and Control	<ul style="list-style-type: none"> • Future and real-time operating conditions with short decision time frames and a high degree of uncertainty in system inputs can be evaluated. • Automation with predictive capabilities, advanced computational solvers, and parallel computing. This includes non-linear optimization of highly stochastic processes. • Decision support to operators in control rooms through pinpoint visualization and cognitive technologies.
4. Develop Enhanced Power Flow Control Device Hardware	<ul style="list-style-type: none"> • Low-cost, efficient and reliable power flow control devices that enable improved controllability and flexibility of the grid.

Topic 1.2.1 – Grid Architecture

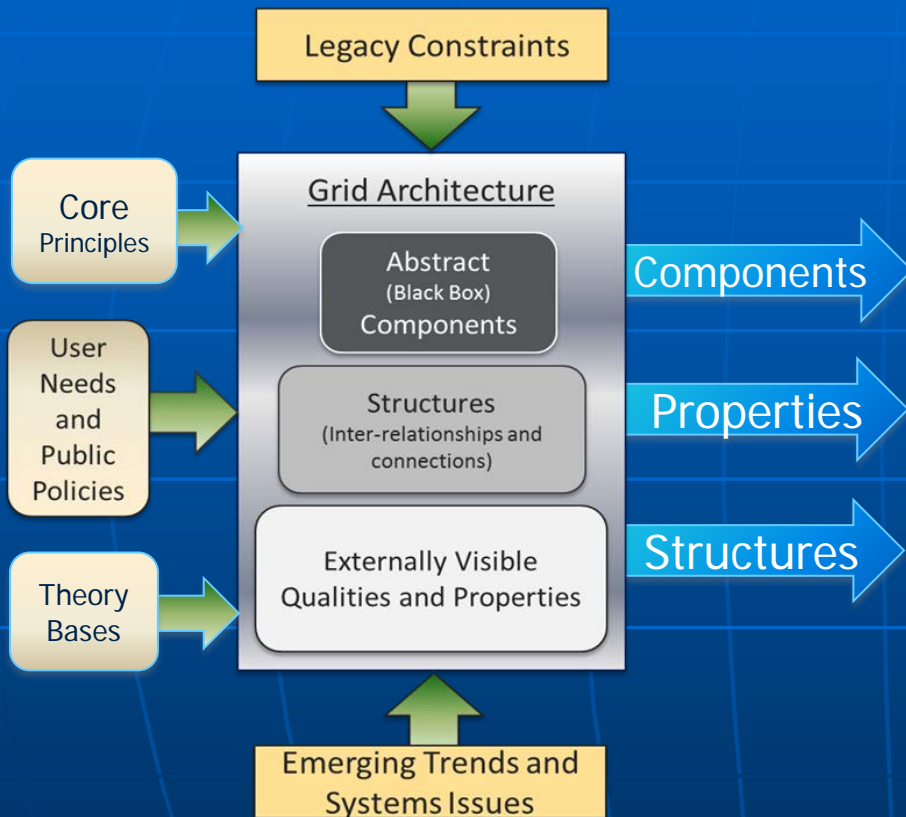

Build a new stakeholder-driven architecture for grid modernization, provide it to the industry along with the tools they need to adapt it to their needs, and use it to inform the playbook for the GMLC program managers. The result will be superior stakeholder decision-making about grid modernization activities of all kinds.

PoP: FY16/17/18

Budget: \$3M

Labs: PNNL, ANL, NREL, ORNL,
LANL, LBNL, LLNL, SNL,

Partners: GE-Alstom, EPRI, GWU, UTC,
SGIP, Omnetric Group, CA ISO

Topic 1.4.10 – Control Theory

Develop new control solutions including topologies, algorithms and deployment strategies for transitioning the power grid to a state where a huge number of distributed energy resources are participating in grid control to enable the grid to operate with lean reserve margins. The theory effort will recognize the need to engage legacy control concepts and systems as we transition to more distributed control.

PoP: FY16/17/18

Budget: \$6.5M

Labs: LANL, PNNL, ANL, INL, NREL, SNL, LLNL

Partners: Oncor Electric Delivery, PJM Interconnection LLC, United Technologies Research Center

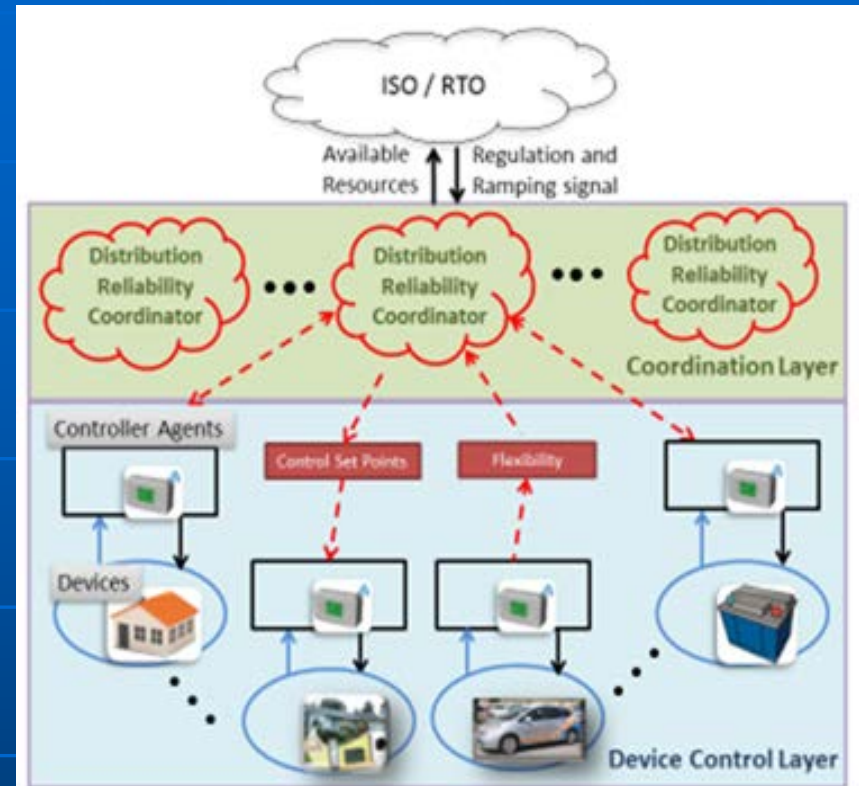
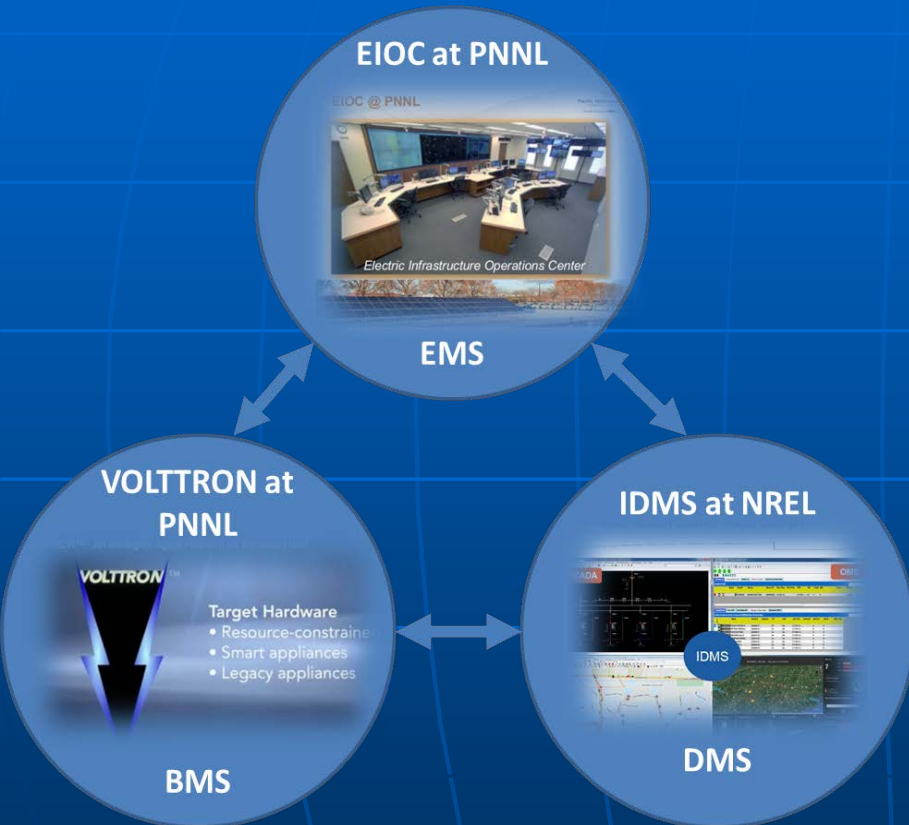

Figure 1: Candidate hierarchical distributed control architecture based on future distribution reliability coordinator model

Topic 1.4.11 – Multi-Scale Integration of Control Systems (EMS/DMS/BMS)

Create an integrated grid management framework for the end-to-end power delivery system – from central and distributed energy resources at bulk power systems and distribution systems, to local control systems for energy networks, including building management systems.



PoP: FY16/17/18

Budget: \$3.5M

Labs: ANL, BNL, LANL, LLNL, NREL, PNNL, SNL

Partners: Alstom Grid, Duke Energy, PJM Interconnection LLC